

**IP/MPLS Routers with Security –
VCL-MX-5050-R / VCL-MX-5010-R / VCL-MX-5020-R /
VCL-MX-5040-R**

- Routing: IPv4, IPv6, OSPFv2/v3, BGPv4, MPLS, VLAN, VRRP, DHCP, NAT, SNMP, IGMP, QoS, Q-in-Q, NAT, MPLS-TE.
- Firewall/Security: IPsec, OpenVPN, PBR, L2VPN, Whitelist and Blacklist options, GRE, Data Encryption and Tunneling .
- 1G, 10G, 40G, 100G interface options
- 1+1 redundant power supply AC/DC options.

Teleprotection (DTPC / Protection Signalling) - VCL-TP

- Stand-alone integrated Teleprotection
 - Bi-directional transmission of 8 binary command Inputs and 8 binary command Outputs
 - External Trip Counter and Alarm Display unit
- Transmission interface options include:
- 8 Binary Commands over E1, 2.048Mbps link
 - 8 Binary Commands over Redundant, 1+1 E1 (2.048Mbps) transmission links with path protection / route protection and automatic failover
 - 8 Binary Commands over IEEE C37.94 Optical link
 - 8 Binary Commands over Redundant, 1+1 IEEE C37.94 Optical transmission links with path protection / route protection and automatic failover
 - 8 Binary Commands over E1 plus IEEE C37.94 Optical, 1+1 redundant transmission links with path protection / route protection with automatic failover
 - 8 Binary Commands over IP/MPLS / MPLS-TP (10/100BaseT RJ45; or 100BaseFX Optical) Ethernet
 - 8 Binary Commands and IEC-61850 GOOSE over E1 plus IEEE C37.94 plus Ethernet (1+N redundant
 - IEC 61850 GOOSE (PSCH1 and PSCH2) over IP/MPLS / MPLS-TP (10/100BaseT RJ45, or 100BaseFX Optical) Ethernet links
 - IEC 61850 GOOSE (PSCH1 and PSCH2) over IP/MPLS / MPLS-TP / Ethernet; plus E1; plus IEEE C37.94 Optical (1+N redundant transmission) links.

Typical Point-to-Point - Application Diagram

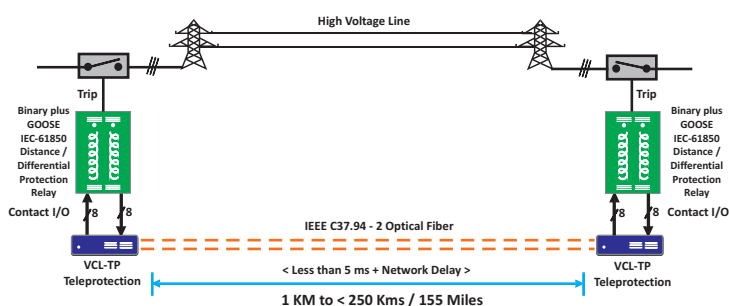

**STM-1/4/16/64 SDH / OC-3/12/48/192 SONET Multiplexers
with MPLS-TP - VCL-1400**

- STM-1, STM-4, STM-16 and STM-64 SDH OC- 12/48/192 / SONET ADM Multiplexer with MPLS-TP up to 100G cross-connect
- Tributary interfaces: PDH (E1,E3/DS3), STM-1, Layer 1 and Layer 2 Ethernet (10/100/1000 BASE-T)
- MPLS-TP support

IEEE C37.94 to Optical equipment - VCL-2710

- Ruggedized, sub-station-hardened IEEE C37.94 Multi-Mode to Single-Mode Optical equipment
- Designed to convert and propagate IEEE C37.94 multi-mode signals over extended 1310nm / 1550nm single-mode optical fiber spans
- Includes clock synchronization and clock re-generation functions which transmits the IEEE C37.94 multi-mode signal over single-mode optical fiber links of up to 45dB, 50dB, 55dB, 65dB optical link loss budget (up to 250Kms / 155 Miles).

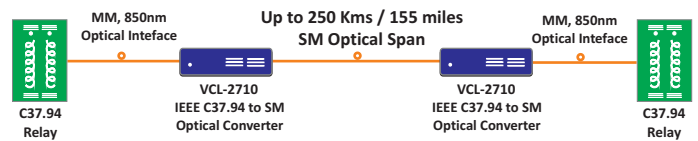

IEEE C37.94 over IP/MPLS / MPLS-TP - VCL-2711

- Ruggedized, sub-station-hardened transmission equipment which converts and transmits upto 4 x IEEE C37.94 Interfaces over Ethernet / IP/MPLS / MPLS-TP link with “SDH/SONET like” performance.
- End-to-end transmission delay (latency) of <math>< 8\text{ms}</math>
- Symmetrical transmission latency with zero transmission errors
- SDH/SONET quality “Jitter” and “Wander” control
- Multiple, integrated clock synchronization options

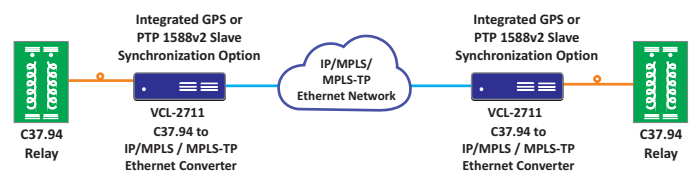

IEEE C37.94 to E1 Converter - VCL-2709 (1E1) / VCL-MX-1554-RAC

- Ruggedized and robust, sub-station-hardened protocol converter that converts the IEEE C37.94 Interface to 2.048Mbps E1 Interface and vice-versa.
- Precise clock recovery and clock re-generation functions which allows transmission of IEEE C37.94 channels over an E1/SDH network for error free transmission.
- Number of IEEE C37.94 interfaces per card: 1 or 4
- Number of interfaces: 1 or 4, E1 (2.048 Mbit/s) Interface(s) (Electrical G.703)

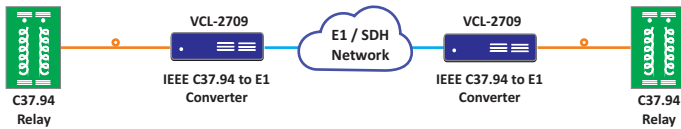

Grid Synchronization - PTP IEEE-1588v2, NTP, GPS/GNSS Primary Reference Clock (G.811)

- GPS/GNSS Primary Reference Clocks (ITU-T G.811)
- NTP Time Servers with IRIG-B
- NTP Server provides up to 16 x 1G/10G NTP outputs and capable of handling up to 1 Million NTP requests per second.
- PTP IEEE-1588v2 Grandmaster
- PTP IEEE-1588v2 Slaves
- PTP IEEE-1588v2 Aware Switch
- SSU (Synchronization Supply Unit) Fully Redundant (1+1) architecture GPS/GNSS, PTP, NTP
- GPS to IRIG-B, NTP to IRIG-B, PTP to IRIG-B
- Time Distribution unit: NTP Client, IRIG-B (RS-422, RS-232, RS-485), IRIG-B optical, 1PPS, NMEA (0183).

E1 DXC / E1 PDH Drop-Insert Multiplexers - VCL-MX

- 160Mbps, 80 E1 digital access cross-connect at 64Kbps
- 1+1 E1 Link, Control Card / Cross-Connect, PSU
- IEEE C37.94 and 4 Binary Command Card Teleprotection

Voice and Data Interfaces

- FXO, FXS, E&M (2 Wire and 4 Wire) and Synchronous / Asynchronous Data: G.703 / V.35 / V.36 / X.21 / RS530 / V.24 / V.11 / V.28 / RS232 / RS485

IEC 60870-5-101 to IEC 60870-5-104 Converter

- Converts IEC-101 data to IEC-104 data

Ruggedized Industrial Switches (L2 & L3)

- 10 ports, 16 ports, 24 ports
- IEC 61850-3 compliant
- 1+1 redundant power supply AC/DC options

Phasor Measurement Unit (PMU) - VCL-PMU-30



- Fully integrated, modular phasor measurement unit (PMU) and control solution designed for Synchrophasor systems
- Wide Area Measurement System (WAMS)
- Meets and exceeds C37.118 requirements for P and M class accuracy
- Integrated GPS Receiver with high precision <50 ns clock base, or IEEE-1588v2 PTP Slave
- Best in Class frequency accuracy of 0.001Hz

VCL-5051, 10G Optical repeater

- Ruggedized and robust, 3-R 10G Repeater that Re-Generates, Re-Shapes, and Re-Times the 10G optical signal so that it may be extended over long distances on optical links.
- Supports point-to-point applications.



Parallel Redundancy Protocol (PRP/HSR) Switch

- VCL-2724 PRP / HSR Switch with zero transmission errors on failover.
- Failsafe: Only product in the industry which (in the electrical ethernet mode) never itself becomes a point of failure, even in power down condition. The “protected interface” automatically reverts to and reconnects to the “primary interface” even in a power down condition.
- IEC 61850-3 compliant
- 1+1 redundant power supply AC/DC options

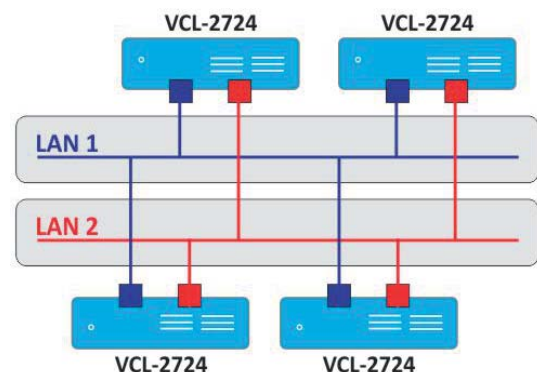

Cyber Security Suite - Prevent, Detect, Secure

VCL-2143: Network MouseTrap™ an Advanced Honeypot:

- Essential part of the digital forensics kit that Detect firewall breaches and unauthorized intrusions in an IP network.
- Provides audio-visual alerts upon detection of a network security breach.
- Fingerprints with timestamp, including IP address, domain, location of the intruder along with forensic analysis in real-time.
- Alerts of a network intrusion / cyber-attack in real-time.
- Assists in identifying trace route and isolating the source of problem / points of network vulnerability by providing forensic analysis in real-time.

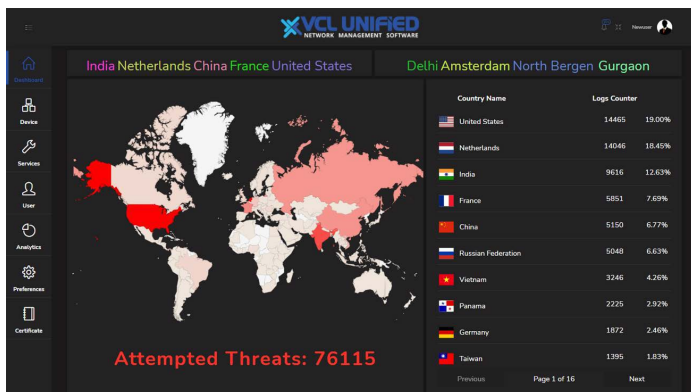

VCL-2702 : Network Isolation (Kill) Switch:

- Designed to assist organizations to prevent and secure their network against firewall breaches and cyber-attacks in real-time
- Provides manual and automatic isolation from network, in a cyber-attack
- Isolates critical assets in the event of the detection of a network intrusion
- Helps create isolated operations zones.

VCL-2243 RTU Firewall:

- High-security, high-reliability, ruggedized, failsafe transparent RTU Firewall
- Designed to be installed between the RTU and the SCADA server without having to reconfigure any element of the network.
- Supports IEC 60870-5-104 (IEC 104), MODBUS TCP/IP protocol options with extremely advanced firewall features to secure and protect RTUs.

VCL-2457: Cyber-Smart Rack with SMS Alerts:

Provides multiple alert and alarm options including fan management and fan failure alerts, smoke alarm, high temperature alarm, open door alarm (upto 6 binary I/Os), NTP/SNTP synchronization, Intelligent Power Distribution Unit and remote monitoring using NMS.

VCL-SafeComm-E: 1+1 Ethernet Failover Protection / AB Fallback Switch

- 1+1 Automatic Ethernet Failover Protection Switches that provide 1+1 Automatic Ethernet Failover / AB Fallback Protection between an "active" and "standby" equipment;
- 1+1 Failover between "main" and "standby" networks which are connected to the network through an IP/Ethernet interface.
- Fail-Safe. The equipment never becomes a point of failure. It automatically reverts to the "primary network" / even in a power down condition.
- Monitors end-to-end link connectivity.
- Provides equipment or network redundancy for applications which require 99.99% up-time.

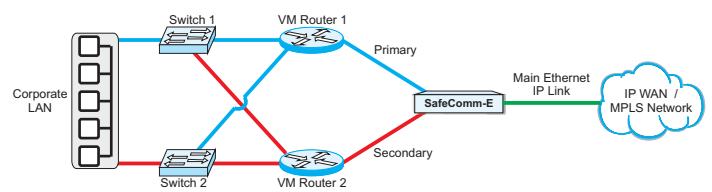

Provides 1+1 Automatic Ethernet Failover Protection between two (Main and Standby) Routers, Servers, Gateways, Terminals, RTUs, etc. to ensure 99.999% network availability to users.

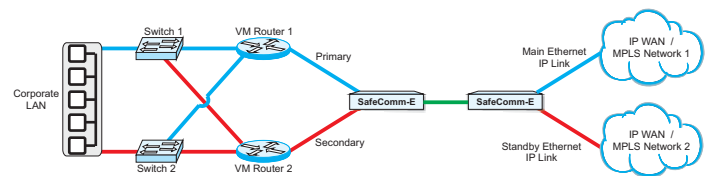

Provides 1+1 Automatic Ethernet Failover Protection between two, IP / Ethernet / MPLS Networks (Primary and Standby Networks).

1+1 Redundant Firewalls:

VCL-MX-5010-F / VCL-MX-5020-F / VCL-MX-5040-F :

- 1+1 redundant configuration firewalls, with automatic fail-over switching.
- Provides advanced protection against cyber threats, Denial of Service (DoS), ransom DDoS (RDDoS) attacks. Designed to secure critical infrastructure such as utilities, sub-stations, smart-grid distribution systems, airports and railways networks as well as IT Networks of financial institutions.

VCL-5001 : Network Traffic Sniffers:

- Detects firewall breaches, network intrusions, data leaks and cyber-attacks in “real-time”.
- Provides the user, the data to conduct forensic analysis and trace the attack route which assists the user to identify the points of network vulnerability and data leaks in their network
- Flags unusual traffic flows for both inbound and outbound traffic by providing an advance warning of data traffic anomalies.

VCL-2142 Enigmatron Xcöde IEC 60870-5-101 / IEC 60870-5-104 / DNP Encryptor (RTU Data Encryption)

- Low data rate encryption equipment with advanced features to secure and protect RTU data in critical infrastructure, Smart Grid Distribution Systems, Oil and Gas Infrastructure and Railway Signalling Networks.
- Provides secure communications between multiple RTU Terminals and their corresponding IEC 60870-5-104, MODBUS-TCP and DNP central server(s).
- Secure and protect IEC -101 / -104 RTU data in critical infrastructure such as Sub-Stations, Smart Grid Distribution Systems, Oil & Gas, Railway Signalling Networks
- 3DES, AES128, AES192, AES256 Encryption Algorithm.

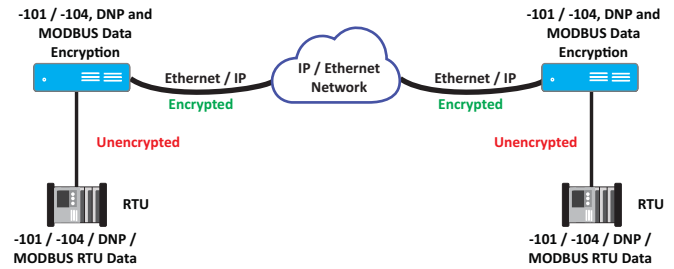

Notes:



Revision 4.1 – October 03, 2023

<p>U.S.A.</p> <p>Valcomm Technologies Inc.</p> <p>4000 Ponce de Leon Blvd., Suite 470, Coral Gables, FL 33146, U.S.A.</p> <p>E-mail: us@valiantcom.com</p>	<p>U.K.</p> <p>Valiant Communications (UK) Ltd.</p> <p>Central House Rear Office 124 High Street, Hampton Hill Middlesex, TW12 1NS, U.K.</p> <p>E-mail: gb@valiantcom.com</p>	<p>INDIA</p> <p>Valiant Communications Ltd.</p> <p>71/1, Shivaji Marg, New Delhi - 110015, India</p> <p>E-mail: mail@valiantcom.com</p>
---	--	--