

Introduction:

VCL-ETH-8E1-ML / VCL-ETH-16E1-ML / VCL-ETH-24E1-ML Converter allows the user to send Ethernet data between two points or between multiple points (maximum 16 directions), over 8/16/24 E1 Links respectively. E1 Interfaces options are 75 Ohms/120 Ohms (Optional – as per user requirement). This equipment provides three Gigabit Ethernet ports (2 x Electrical 1000/100/10M and 1 x SFP based Optical) at the customer site.

The equipment supports point-to-point - multilink protocol which allows a single unit to be connected to multiple units (maximum 16) at the same time to transport Ethernet data from multiple sites to a single central location.



This equipment is available in the following configurations:

E1 Interface Number	8 or 16 or 24
E1 Port Impedance option	75 Ohms (BNC) / 120 Ohms (Rj45) – Optional
Power Supply Options	AC or DC or AC+DC-Redundant AC = 100 ~ 240 VAC, 50 / 60 Hz DC = 18 ~72 VDC

This product is available in three versions:

VCL-ETH-8E1-ML	8 E1 Port Version
VCL-ETH-16E1-ML	16 E1 Port Version
VCL-ETH-24E1-ML	24 E1 Port Version

The equipment can be installed (at central site) and used with other equipment (i.e. with Ethernet over Multi E1 - DLX or VCL-ETH-FE1 at remote sites) to meet various application requirements.

The Converter is an Ethernet extension device, complied to IEEE 802.3 series standards, which utilizes TDM telecom infrastructure (the telecom network of E1s, or of PDH, SDH and E1 / E3 / SDH microwave etc.), complied to ITU-T G.7041, G.7042, G.7043 and G.8040 standards, for carrying Ethernet data. It converts the Ethernet data into E1 frame format for transmission over the existing TDM (E1) links and then re-converts the E1 back into Ethernet data at the far-end terminal, to BRIDGE Ethernet LANs over the existing E1 based telecom network. The device can effectively utilize the existing TDM network to transport Ethernet data at low investment.

Alarms and Indicator Monitoring

- Power Indicator
- Run (in-operation) Indicator
- General Alarm Indicator for E1 and Ethernet Link
- E1 LOS Alarm for individual E1 port (1-24)
- Code Violation History (CV_HIS) Alarm on E1 port
- Ethernet Link Indicator
- Ethernet Speed Indicator
- SNMP Diagnostic and Monitoring.

Features and Highlights

- Supports point to multipoint, up to 16 directions and 24 E1 Links capacity.
- 1U high compact size.
- Provides 3 x Gigabit Ethernet ports
 - 2 x Electrical 1000/100/10M,
 - 1 x SFP based Optical.
- Supports VCAT (virtual concatenation) and LCAS (Link Capacity Adjustment Scheme) protocol, and complies with ITU-T G.7042 Specifications
- Supports auto removal of down E1 link and auto insertion of recovered E1 link.
- Mapping to E1 complies with ITU-T G.7043 and G.8040 specifications
- Supports VLAN tagging as per 802.1Q
- User selectable ports for enabling / disabling the QoS service
- Supports differential delay of up to 220ms on E1 Links
- Complies with IEEE 802.3ab, IEEE 802.3u and IEEE 802.3 specifications
- Supports X.86, LAPS and HDLC transmission protocols
- Supports 10M / 100M /1000M, Half / Full duplex and auto-negotiate mode.
- Configurable frame size upto 1552 bytes (MTU size)
- Supports GFP-F encapsulation complying with ITU-T G.7041
- Provides automatic smooth adjustment of Ethernet bandwidth as per the availability of carrier (E1) links
- Provides error frame statistic
- Supports automatic removal and addition of E1 Links without interrupting current services
- Available with MAC address list filtration, learning and updating functions
- A large external SDRAM buffering for handling data bursts
- 8000 MAC address learning
- Support configurable MAC aging time 12 / 300 seconds
- Supports internal synchronization clock
- Automatic straight and cross-over cable support (Auto-MDI/X).

Salient Features:

- Connect multiple sites (up to 16 directions) from a single central location
- Data rate recovery after restoration of lost E1 (LCAS)
- Automatic data rate management according to number of available E1 links
- Maximum cable length supported (upto 1000 feet / 333 meters)
- Support unbalanced bandwidth- If Rx line of some E1 links are not working then the equipment will keep working on Tx line, to use unbalanced bandwidth. i.e. If Tx of a E1 line is not working out of 5 E1 available then the equipment will continue to send data on 4 E1s and receive on 5 E1s and vice-versa.

Application

The equipment may be used for the following purposes:

- Bridging Ethernet LANs over existing TDM (E1) telecom network
- Extending Ethernet networks utilizing TDM (E1) landline based telecom infrastructure.
- Using telecom network of E1s/PDH/SDH microwave etc. carrying E1s to transport Ethernet data.
- Interconnecting DSLAMS to Central Routers over PDH/SDH telecom networks.
- Interconnecting IP-based GSM base stations.
- Interconnecting WiMax base stations.

In all cases, the equipment must be always installed and used in pairs, with one terminal being installed at either end of the network.

Technical Specifications

E1 Interface Specifications

Number of E1	8/16/24 E1 Interfaces (optional)
Line Rate per E1	(2.048 Mbps \pm 50 bps)
Line Code	HDB3
Framing Structure	As per ITU (CCITT) G.704
Framing Options	Un-Framed
Electrical	As per ITU-T G.703
Jitter	As per ITU-T G.823
Impedance	120 Ohms
Nominal Pulse Width	244ns
Connector	RJ-45 (Female)

Ethernet Interface Specifications – 10/100/1000BaseT (Electrical)

Number of Ethernet Interfaces	3
Interface types	2 x 10/100/1000BaseT + 1 GigE Optical
Standards compliance	IEEE 802.3 / 802.3u/ 802.3ab
Transmission bit rate	10/100/1000BaseT
MTU size (frame size)	Upto 1552 bytes
Connectors	RJ-45 (10/100/1000BaseT Electrical) + SFP based Optical
Supports	VLAN tagging as per 802.1Q

WAN Protocol

Type	ML-PPP
MTU size	Upto 1552 bytes
Delay compensation	Upto 220 ms
Supports VCAT (virtual concatenation) and LCAS (link capacity adjustment scheme) protocol, and complies with ITU-T G.7042 Specifications	
Mapping to E1 complies with ITU-T G.7043 and G.8040 specifications	
Supports X.86, LAPS and HDLC transmission protocols	
Supports GFP-F encapsulation complying with ITU-T G.7041	

Internet Bridge

LAN Table	Learns upto 8,000 MAC Addresses
Operation Mode	VLAN-aware, VLAN-unaware
Filtering and Forwarding	Transparent or filtered

Management Control

- 10/100/1000BaseT Ethernet management interface
- RS232 serial management interface
- Remote (Telnet) management interface
- Windows XP-based Graphical User Interface (GUI)
- Windows 7-based Graphical User Interface (GUI)
- SNMP V2 Monitoring
- NMS (Network Management System) for monitoring multiple units from a single / central location.

Management Control

- Serial Management Port (RS232) – Console Port
- 10/100 BaseT Port for Telnet and SNMP Management

E1 (120 Ohms) RJ-45 (Female) Pinout details

PIN No.	Definition of function Signal	Direction
1	TX+ (transmitted data +)	E1 Data Input
2	TX- (transmitted data -)	E1 Data Input
3	NC	
4	RX+ (received data +)	E1 Data Output
5	RX- (received data -)	E1 Data Output
6	NC	
7	NC	
8	NC	

Ethernet RJ-45 (Female) Pinout details

PIN No.	Definition of function Signal	Direction
1	TX+ (transmitted data +)	Data Output
2	TX- (transmitted data -)	Data Output
3	RX+ (received data +)	Data Input
4	NC	
5	NC	
6	RX- (received data -)	Data Input
7	NC	
8	NC	

Power Supply (Optional)

AC Mains Input	220V \pm 20% (AC Mains Input Model)
DC Mains Input	-48V DC (DC Mains Input Model)
Power Consumption	\leq 12W

Service Conditions

Ambient / operating temperature	-20°C ~ +70°C
Relative humidity	\leq 90% (at 35°C)
Storage temperature	-25 to 85°C

Mechanical Specification

- H x D x W: 45mm x 210mm x 480mm.
- Weight: 2.8kgs.

Application Diagram

Point-to-point Application: Shared Link Mode

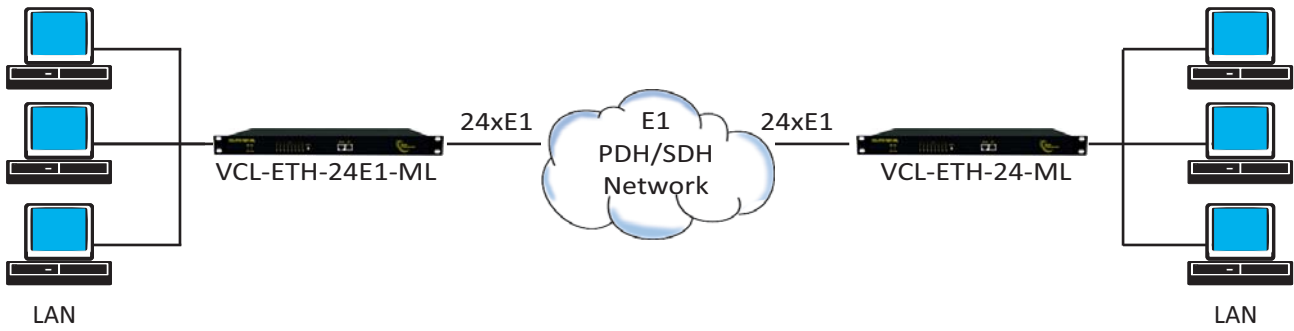

Point-to-point Application: Discrete Link Mode

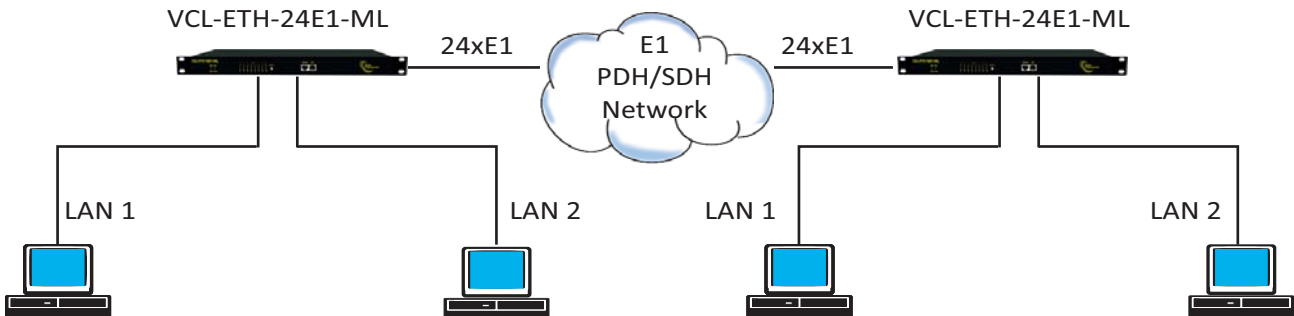

Point-to-Multi-point Application: 1

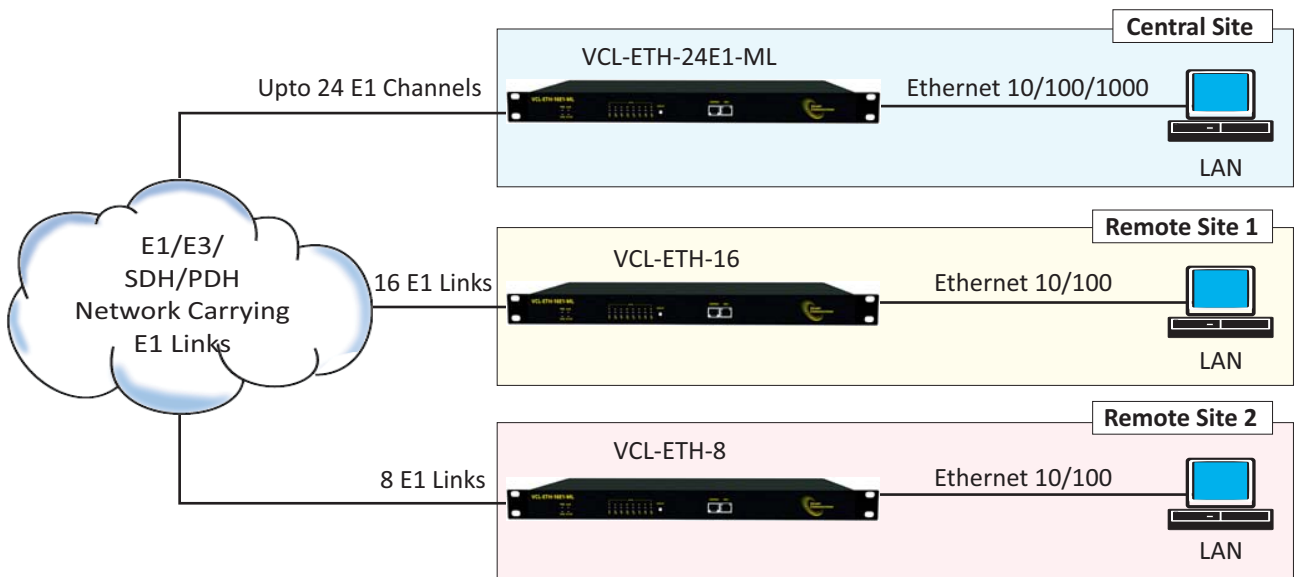

Point-to-Multi-point Application: 2

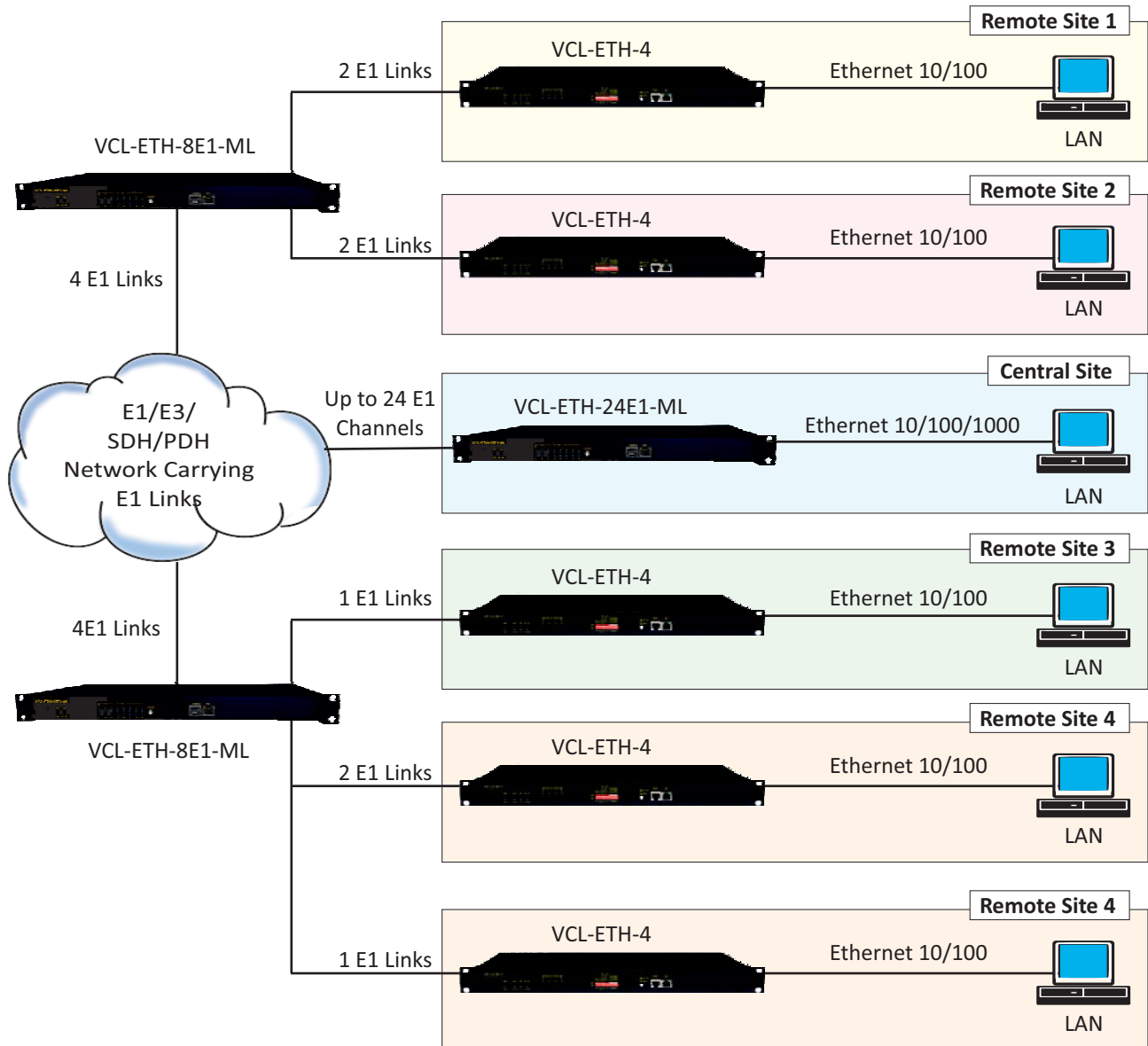

Point-to-Multi-point Application: 3

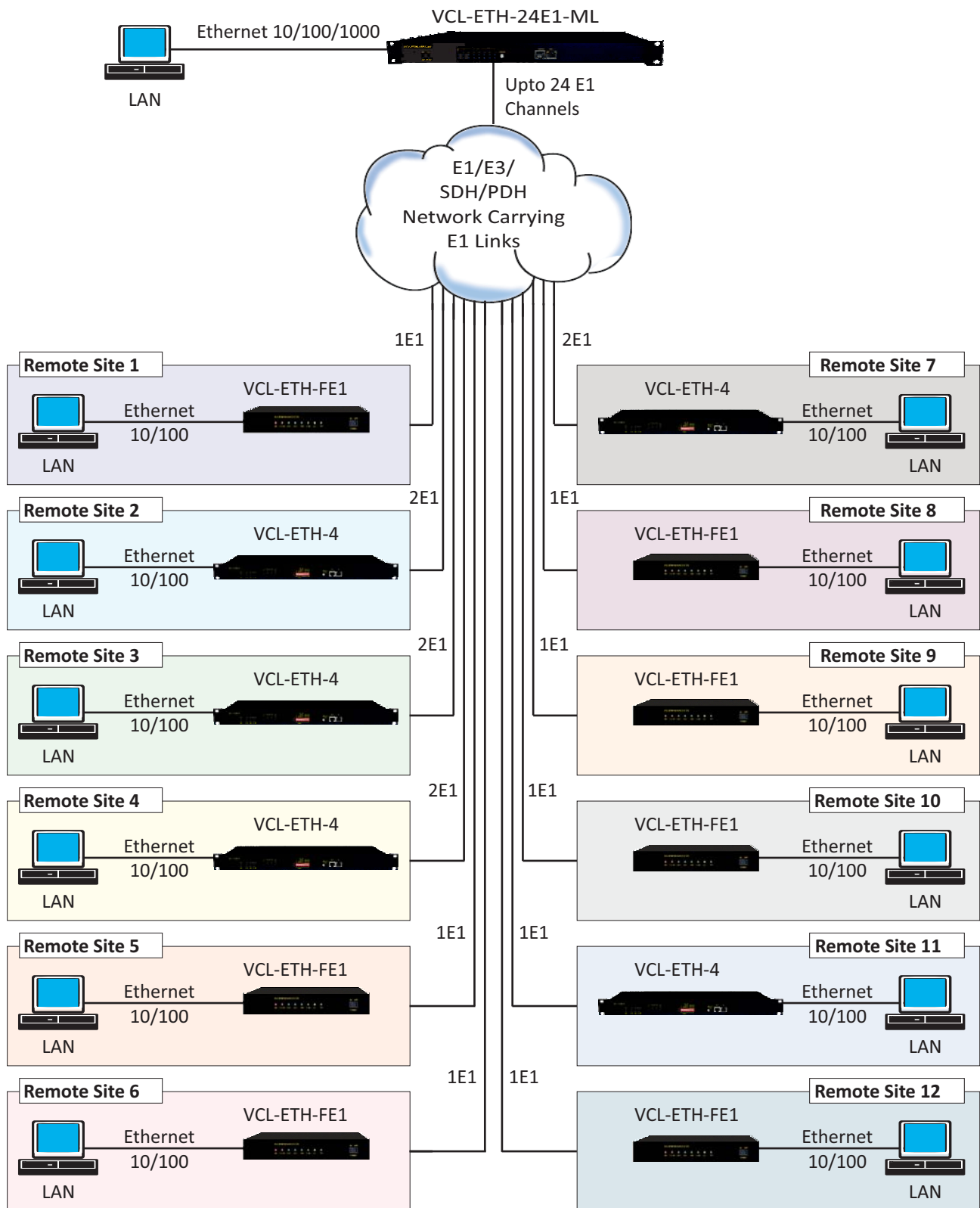

Up to 16 Remote Sites / Directions and 24 E1 Links

Ordering Information

Ethernet over 8E1, 16E1 and 24E1 - Point to multi-point

Part #	Product Description
VCL-0432-GigE	<p>VCL-Gigabit Ethernet over Multi E1 (8E1 / 16E1 / 24E1): 3Ethernet over E1 (10/100/1000M over E1): Interface conversion bet. G.703 E1 and each 10BaseT (Ethernet over E1 / TDM) 19" Shelf 1U High Rack-Mount Version Supports :</p> <ul style="list-style-type: none"> - 3 x Ethernet Ports (1000Mbps, Gigabit) - 2 x Electrical Ethernet Ports [RJ45 (F)] - 1 x Optical Ethernet Ports [SFP based / without SFPs] - E1 Options [# Add E1 Options (E1O) from below] - Installation Kit: System Core Cables, Mounting Hardware, Documentation, User Manual - Management: CLI, GUI, SNMP <p>^ Suitable for Point-to-Point / Multi Point applications * Add Power Supply Option from below (PSU)</p>

Power Supply Options

S. No.	Option	Description
1	AC	1 x 100~240V AC Power Supply Input
2	DC	1 x 48V DC Power Supply Input
3	AC+DC	1 x 110~240V AC Power Supply Input 1 x 48V DC Power Supply Input
4	ACR	2 x 100~240V AC Power Supply Input
5	DCR	2 x 48V DC Power Supply Input

E1 Impedance Options

S. No.	Option	Description
1	08E1-ML-120	8 x E1 [120Ω RJ45 (F)] [8VCG - 8 Channel]
2	08E1-ML-075	8 x E1 [75Ω DB37 (M) with DB37 (F)-BNC (F) Cable Adapter] [8VCG - 8 Channel]
3	16E1-ML-120	16 x E1 [120Ω RJ45 (F)] [16VCG - 16 Channel]
4	16E1-ML-075	16 x E1 [75Ω DB37 (M) with DB37 (F)-BNC (F) Cable Adapter] [16VCG - 16 Channel]
5	24E1-ML-120	24 x E1 [120Ω RJ45 (F)] [16VCG - 24 Channel]
6	24E1-ML-075	24 x E1 [75Ω DB37 (M) with DB37 (F)-BNC (F) Cable Adapter] [16VCG - 24 Channel]

Gigabit SFP Options

S. No.	Option	Description	Remarks
1	VCL-EMOD 0231	1.25Gbps SFP Transceiver, Duplex LC, 1310nm, 15Km, SMF	Maximum 1 SFP for Optical Ethernet
2	VCL-EMOD 0255	1.25Gbps SFP Transceiver Duplex LC, 1310nm, 40Km, SMF	
3	VCL-EMOD 0256	1.25Gbps SFP Transceiver Duplex LC, 1550nm, 80Km, SMF	

Technical specifications are subject to changes without notice.

All brand name and trademarks are the property of their respective owners.

Revision – 10, May 26, 2022

U.S.A.

Valcomm Technologies Inc.
 4000 Ponce de Leon Blvd.,
 Suite 470, Coral Gables,
 FL 33146, U.S.A.

E-mail: us@valiantcom.com

U.K.

Valiant Communications (UK) Ltd
 Central House Rear Office
 124 High Street, Hampton Hill
 Middlesex, TW12 1NS, U.K.

E-mail: gb@valiantcom.com

INDIA

Valiant Communications Limited
 71/1, Shivaji Marg,
 New Delhi - 110015,
 India

E-mail: mail@valiantcom.com